

Deluxe Fan-Light Combination with Round Polymeric Grille MODEL: 8664RP

DESCRIPTION

- White polymeric grille impervious to bathroom climate.
- Powerful Deluxe Fan-Light Combination units quietly remove stale, steamy air from bathrooms up to 95 sq. ft., other rooms up to 125 sq. ft.
- Glass lens brightly diffuses 100 watt bulb (purchase bulb locally). Lens extends only 1 $\frac{5}{8}$ " from finished ceiling.
- Polypropylene blower wheel performs efficiently with a minimum of sound.
- Tapered duct adapter with built-in damper for easy installation to 4" duct.
- May be wired for simultaneous or separate fan light operation.
- This model is UL listed for use in a tub/shower stall enclosure when used with GFI branch circuit wiring.
- Refer to NuTone's catalog for a complete line of accessories to effectively adapt these units to your construction requirements.
- Type IC for use with thermal insulation.

DESIGN FEATURES

- Air Delivery:** 100 CFM.
Sound Level: 3.5 Sones.
Dimensions: **Housing:** 9" x 9" x 5 $\frac{3}{4}$ " deep.
Grille: 14 $\frac{1}{8}$ " diameter x 1 $\frac{1}{2}$ " deep.
Reflector: 9 $\frac{3}{4}$ " diameter.
Lens: 9 $\frac{7}{8}$ " diameter.
Cutout: 13 $\frac{1}{4}$ " diameter.
- Material & Finish:** **Housing:** Galvanized steel.
Grille: Polymeric, white finish.
Reflector: Steel, white powder coat finish.
Lens: Frosted Glass.
- Motor:** Shaded pole (round) 4-pole, continuous duty, 115 volts, 1.2 amps, 60 Hz, thermally protected, vertical operating position.
- Blower Wheel:** Centrifugal, polypropylene.
Duct Size: 4" diameter.
Electrical Rating: 120V, 60Hz, 1.9A.

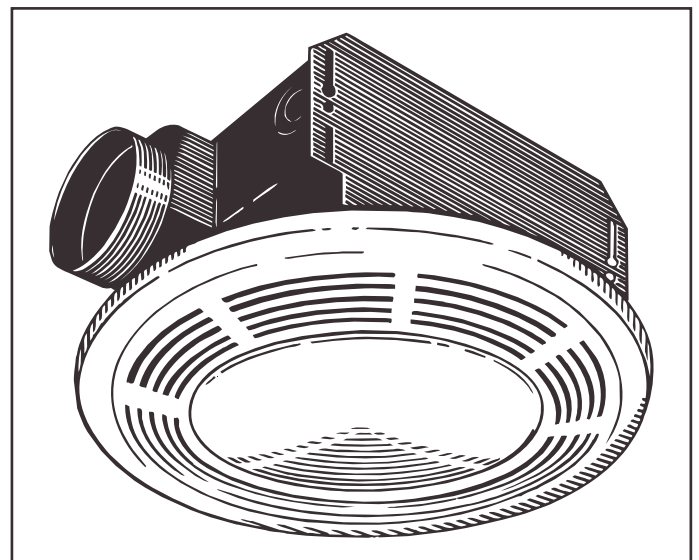

INSTALLATION

- Not for use in kitchens.
- Complete installation instructions are included with each unit.

ARCHITECT'S SPECIFICATIONS

Fan-Light Combination shall be Model Number 8664P as manufactured by NuTone according to listed specifications. Unit shall deliver 100 CFM at a sound level of 3.5 Sones. Housing shall measure 9" x 9" x 5 $\frac{3}{4}$ " deep and connect to 4" diameter duct.



CERTIFIED TEST DATA

HVI-2100 CERTIFIED RATINGS comply with new testing technologies and procedures prescribed by the Home Ventilating Institute, for off-the-shelf products, as they are available to consumers. Product performance is rated at 0.1 in. static pressure, based on tests conducted in AMCA's state-of-the-art test laboratory. Sones are a measure of humanly-perceived loudness, based on laboratory measurements. This NuTone model is listed by Underwriters' Laboratories Inc.

The air delivery of a ventilating system may be determined by:

1. Determine the equivalent duct length for each 90 degree elbow by adding one foot of duct length for each inch of duct diameter, i.e., a 4 inch diameter duct elbow equals 4 feet equivalent duct length and an 8 inch diameter duct elbow equals 8 feet equivalent duct length.
2. Add the total straight length of duct and the equivalent length for each elbow to obtain the total equivalent duct length.
3. Locate the intersection of the fan performance curve and the total equivalent duct length curves and draw a vertical line down to the CFM scale and read the system air performance.
(NOTE: 3 1/4" x 10" duct equals 6 inch diameter duct.)

AIR PERFORMANCE CURVE
(4 In. Duct to 10 Foot Lengths)

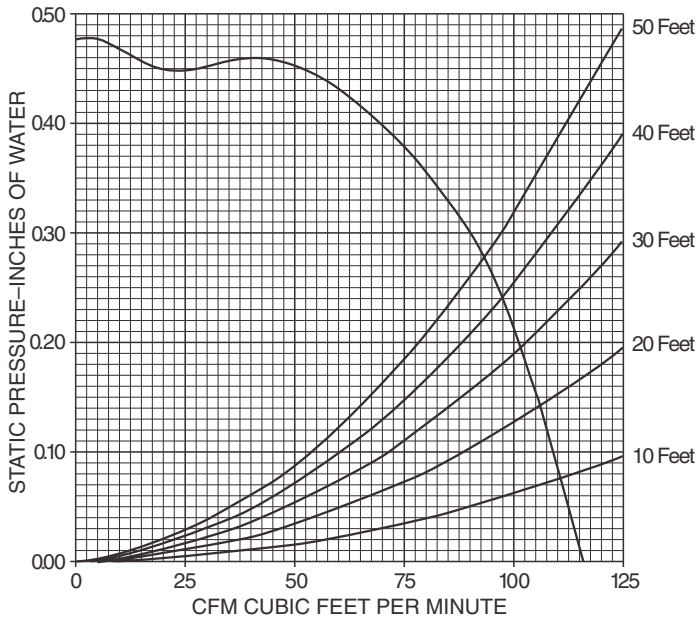

STATIC PRESSURE INCHES OF WATER	0.05	0.1	0.15	0.2	0.25	0.3	0.35	0.4	0.45
CFM	112	108	105	101	96	90	81	70	52

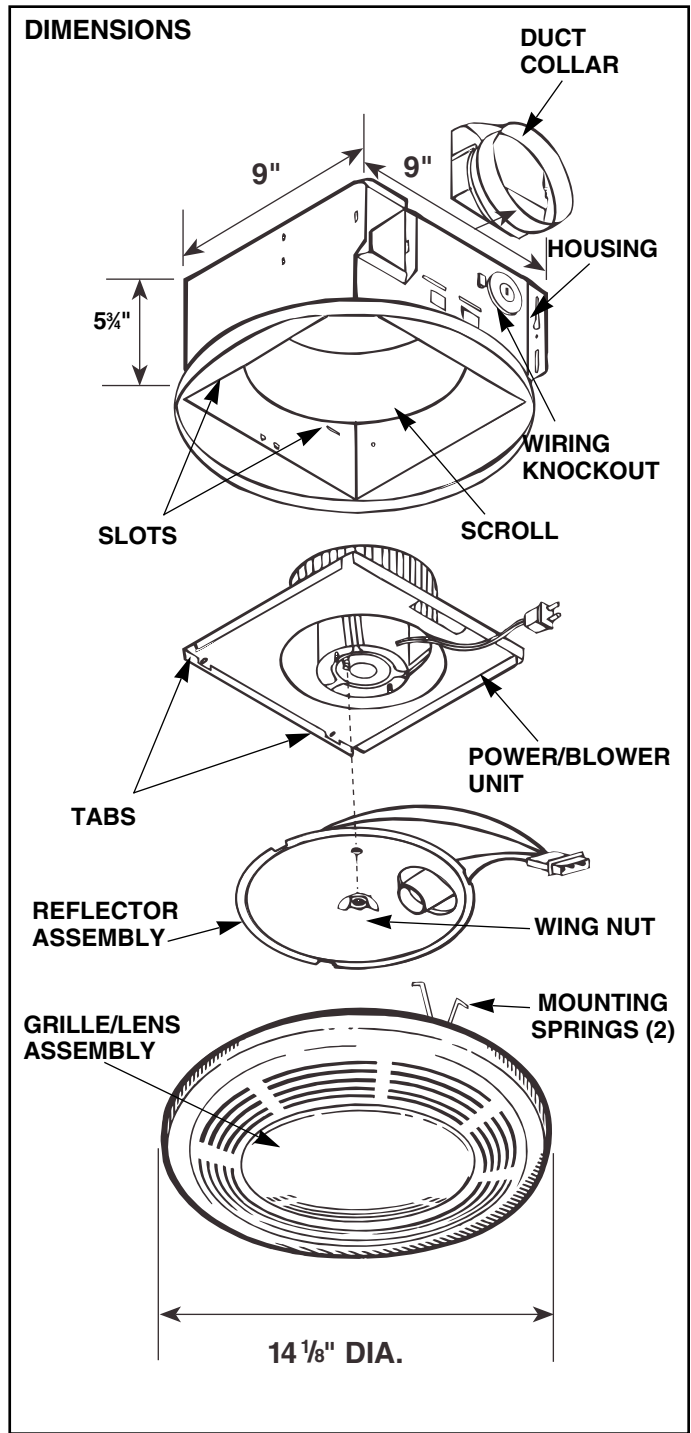

Product specifications subject to change without notice.

NuTone, Inc., 4820 Red Bank Road, Cincinnati, Ohio 45227
Printed in U.S.A.