

Ceiling/Wall Blower

MODELS: 696N

DESCRIPTION

- For baths up to 45 sq. ft., other rooms up to 60 sq. ft.
- Installs in ceiling or 2" x 4" wall studs.
- Mounts on either 16" or 24" O.C. joist or stud.
- Discharge is through 3" round duct through roof or wall.
- Sturdy mounting brackets of double metal thickness slotted on housing for vertical mounting adjustments.
- Extra large outlet box area.
- Efficient impeller blower wheel.
- Attractive white polymeric grille with torsion springs to adjust for thickness variances in ceiling or wall.
- Polypropylene weather damper.
- Refer to NuTone's catalog for a complete listing of accessories to effectively adapt this Bathroom Fan to your construction requirements.

DESIGN FEATURES

- Air Delivery:** 50 CFM at 0.10" S.P.
Sound Level: 4.0 Sones.
Dimensions: **Housing:** 7½" long x 7¼" wide x 3⅝" high.
Grille: 9½" long x 8⅛" wide x 1⅞" thick.
- Material & Finish:** **Housing:** Galvanized steel.
Grille: White Polymeric.
- Motor:** Shaded pole, thermally protected, 120vAC, 60 Hz, .7 amp.
- Blower Wheel:** One-piece polypropylene.
Duct Size: 3" diameter.

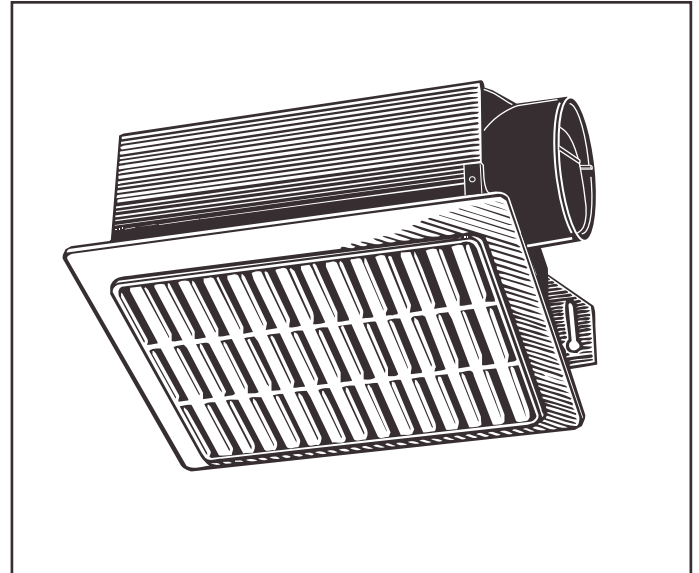

ARCHITECT'S SPECIFICATIONS

Exhaust Fan shall be NuTone Model Number 696N as manufactured by NuTone according to listed specifications. Fan shall ventilate 50 CFM at 0.10" S.P. at a sound level of 4.0 Sones. Housing shall be 7½" x 7¼" x 3⅝" and connect to 3" duct.

INSTALLATION

- Snap on plastic duct transition.
- Not for use in kitchens.
- Suitable for use over tub or shower enclosure when installed in a GFI protected branch circuit.
- Not for use with solid-state speed controls.
- Install in ceiling or 2" x 4" wall studs. "A" unit housing installed during rough-in stage of construction. Power unit assembly and grille are installed when ceiling or wall is finished.
- Torsion springs on grille adjust for thickness variances in ceiling or wall.
- Use a standard on-off toggle switch (purchased separately). Installation Instructions are included with each unit.



CERTIFIED TEST DATA

HVI-2100 CERTIFIED RATINGS comply with new testing technologies and procedures prescribed by the Home Ventilating Institute, for off-the-shelf products, as they are available to consumers. Product performance is rated at 0.1 in. static pressure, based on tests conducted in AMCA's state-of-the-art test laboratory. Sones are a measure of humanly-perceived loudness, based on laboratory measurements. This NuTone model is listed by Underwriters' Laboratories Inc.

The air delivery of a ventilating system may be determined by:

1. Determine the equivalent duct length for each 90 degree elbow by adding one foot of duct length for each inch of duct diameter, i.e., a 4 inch diameter duct elbow equals 4 feet equivalent duct length and an 8 inch diameter duct elbow equals 8 feet equivalent duct length.
2. Add the total straight length of duct and the equivalent length for each elbow to obtain the total equivalent duct length.
3. Locate the intersection of the fan performance curve and the total equivalent duct length curves and draw a vertical line down to the CFM scale and read the system air performance.

(NOTE: 3/4" x 10" duct equals 6 inch diameter duct.)

AIR PERFORMANCE CURVE (3 In. Duct to 10 Foot Lengths)

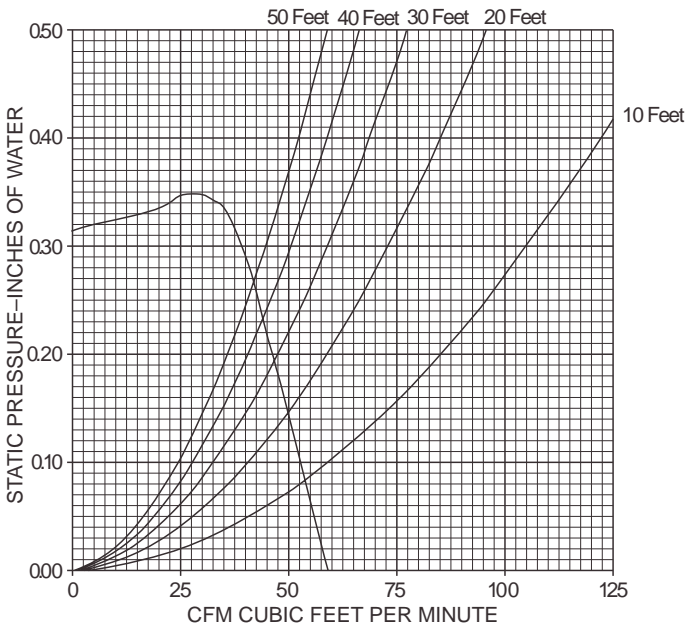

STATIC PRESSURE INCHES OF WATER	0.05	0.1	0.15	0.2	0.25	0.3	0.35
CFM	56	52	49	47	43	39	30

DIMENSIONS

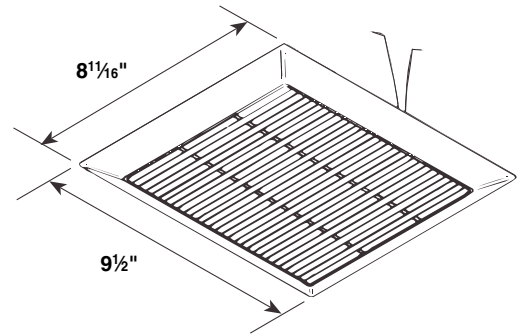
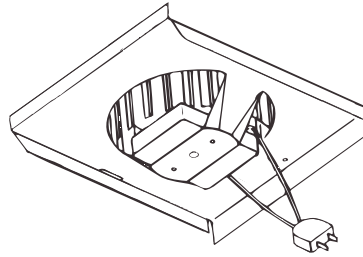
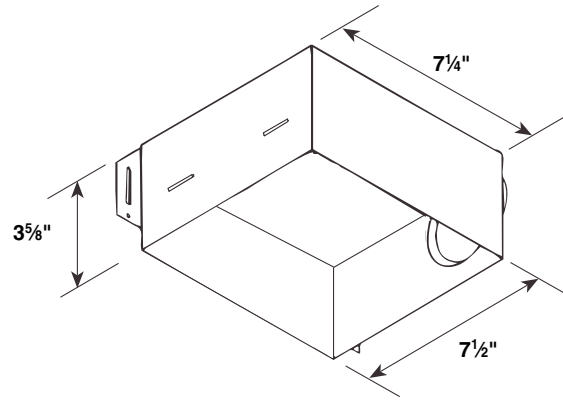

Product specifications subject to change without notice.

NuTone, Inc., 4820 Red Bank Road, Cincinnati, Ohio 45227
Printed in U.S.A.