

Vertical Discharge Fan

MODEL: 686

DESCRIPTION

- For baths up to 75 sq. ft., other rooms up to 100 sq. ft.
- Mounts in ceiling, discharges through 7" duct to roof or wall.
- Housing features welded-on mounting brackets.
- Quiet, efficient, electronically-balanced fan blade.
- Quick-mounting motor, motor brackets fasten into place over two (2) mounting screws in housing.
- White polymeric grille fastens with thumbscrew.
- Switch operated; Aluminum damper opens when fan is turned on; shuts tight when the fan is off.
- Prewired junction box, optional knockouts, plug-in, UL listed for use in tub/shower enclosures when use with GFI branch circuit wiring receptacle.
- Refer to NuTone's catalog for a complete listing of accessories to effectively adapt this Fan to your construction requirements.

DESIGN FEATURES

- Air Delivery:** 80 CFM.
Sound Level: 6.0 Sones.
Dimensions: **Housing:** 6½" x 6¹⁵/₁₆" diameter.
Grille: 8¹¹/₁₆" x 9½".
Material & Finish: **Housing:** Galvanized steel.
Grille: White polymeric.
- Motor:** Plug-in, thermally protected
- Blower Wheel:** One-piece polymeric, 5 leaf.
- Duct Size:** 7" diameter.
- Electrical Rating:** 120v, 60Hz, 1.5Amp

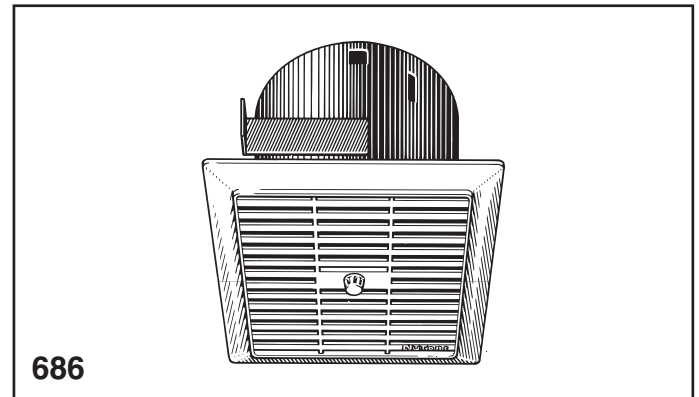

ARCHITECT'S SPECIFICATIONS

Exhaust Fan shall be NuTone Model Number 686 as manufactured by NuTone according to listed specifications. Fan shall ventilate 80 CFM at 0.10 S.P. at a sound level of 6.0 Sones. Fan shall exhaust vertically through 7" round duct.

INSTALLATION

- Suitable for use over tub or shower enclosure when installed in a GFI protected branch circuit.
- Housing has 2 welded-on brackets to fasten onto joists.
- Discharge through 7" round duct to roof or wall.
- Prewired outlet box has 3 knockouts for choice of wiring, plug-in receptacle.
- Motor bracket has keyhole slots for ease of installing Motor Assembly with screws in Housing.
- Installation Instructions included with each unit.

VENTILATION GUIDE

Wall and Ceiling Fans	Recommended Air Changes/Hour	Formula (8 ft. ceiling)
Bathroom	8	Sq. ft. of floor x 1.07 = CFM (i.e. 55 sq. ft. x 1.07 = 60 CFM, rounded)
Recreation Room, Utility or Laundry Room, Basement, etc.	6	Sq. ft. of floor x 0.8 = CFM (i.e. 150 sq. ft. x 0.8 = 120 CFM)

Formulas are based on 8 ft. standard ceiling height. For each additional 2 ft. of ceiling height, add 25% to required CFM figure.

CERTIFIED TEST DATA



HVI-2100 CERTIFIED RATINGS comply with new testing technologies and procedures prescribed by the Home Ventilating Institute, for off-the-shelf products, as they are available to consumers. Product performance is rated at 0.1 in. static pressure, based on tests conducted in AMCA's state-of-the-art test laboratory. Sones are a measure of humanly-perceived loudness, based on laboratory measurements. This NuTone model is listed by Underwriters' Laboratories Inc.

The air delivery of a ventilating system may be determined by:

1. Determine the equivalent duct length for each 90 degree elbow by adding one foot of duct length for each inch of duct diameter, i.e., a 4 inch diameter duct elbow equals 4 feet equivalent duct length and an 8 inch diameter duct elbow equals 8 feet equivalent duct length.
2. Add the total straight length of duct and the equivalent length for each elbow to obtain the total equivalent duct length.
3. Locate the intersection of the fan performance curve and the total equivalent duct length curve and draw a vertical line down to the CFM scale and read the system air performance.

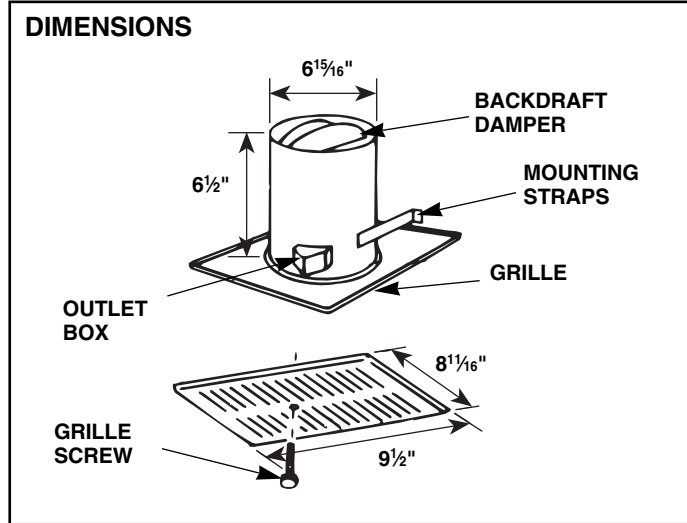

AIR PERFORMANCE CURVE
(7 In. Duct)

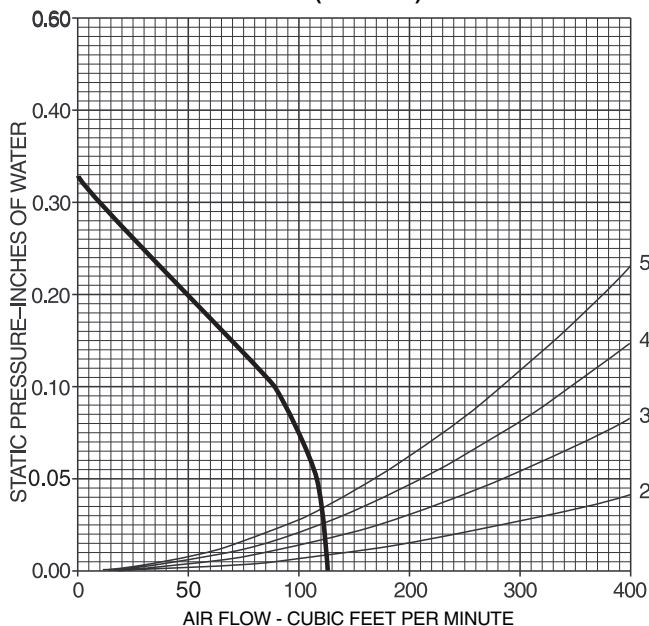

STATIC PRESSURE (INCHES OF WATER)	0.05	0.1	.125	0.15	0.2	0.25	0.3
Air flow (CFM)	105	87	77	66	47	30	11

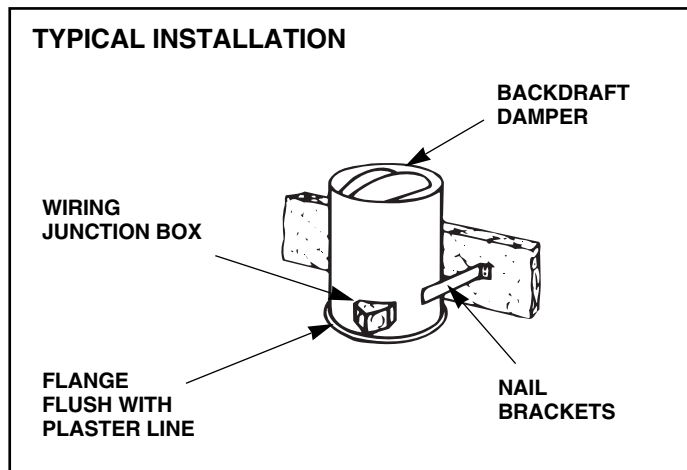

Product specifications subject to change without notice.

NuTone, Inc., 4820 Red Bank Road, Cincinnati, Ohio 45227
Printed in U.S.A.