

MODEL 682NT DUCTLESS CEILING/WALL FAN

MODEL 682LNT DUCTLESS FAN/LIGHT

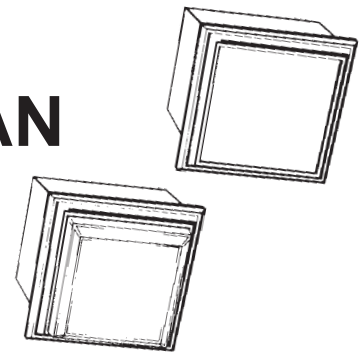

Processes air to eliminate odors where ductwork is impossible.

FEATURES

GRILLE:

- Attractive, self-adjusting grille conceals fan interior
- White, polymeric - blends well with any decor
- Torsion spring grille mounting - no tools required
- Built-in light diffusing lens accepts up to 100 W bulb (Model 682LNT Only - bulb not included)

MOTOR:

- Plug-in, removable motor assembly
- Polymeric impeller

HOUSING:

- Patented snap-in mounting saves time and money
- Mounts easily to framing
- Long-lasting activated charcoal filter - easy to replace

Controls designed for use with these products (purchase separately):

- Model 57V (Ivory) / 57W (White) Electronic Variable Speed Control - 3 amp
- Model 69V (Ivory) / 69W (White) Single-Function Control
- Model 68V (Ivory) / 68W (White) Two-Function Control

NOTE: For installation in ceilings up to 12/12 pitch

SPECIFICATIONS

MODEL	VOLTS	AMPS
682NT	120	1.0
682LNT	120	1.5



TYPICAL SPECIFICATION

Ventilator shall be NuTone Model 682NT (Broan Model 682LNT).

Unit shall have steel housing with snap-in mounting system.

Fan to have activated charcoal filter. Motor assembly shall be removable for cleaning and service.

Grille to be self-adjusting and require no tools to install or remove. Lamp capacity must be 100 Watts (Model 682LNT).

Unit shall be U.L. Listed.

Must be Type I.C. (Model 682LNT only).

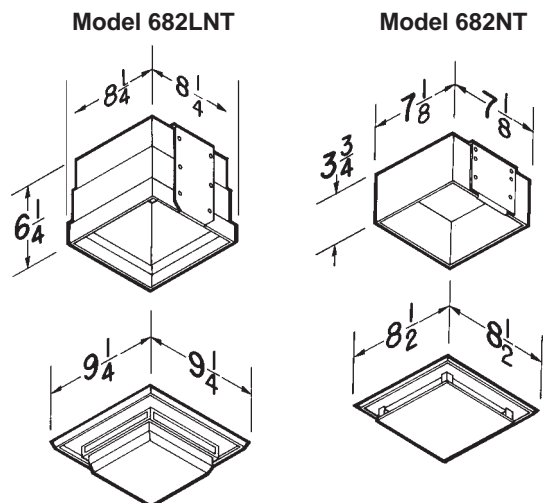

NuTone, Inc., Madison and Red Bank Roads, Cincinnati, OH 45227 (1-888-336-6151)
Product specifications subject to change without notice

REFERENCE	QTY.	REMARKS	Project
			Location
			Architect
			Engineer
			Contractor
			Submitted by Date