

The Bourbon Street[®]

FP510 / FP520 / FP540 / FP550 / FP580

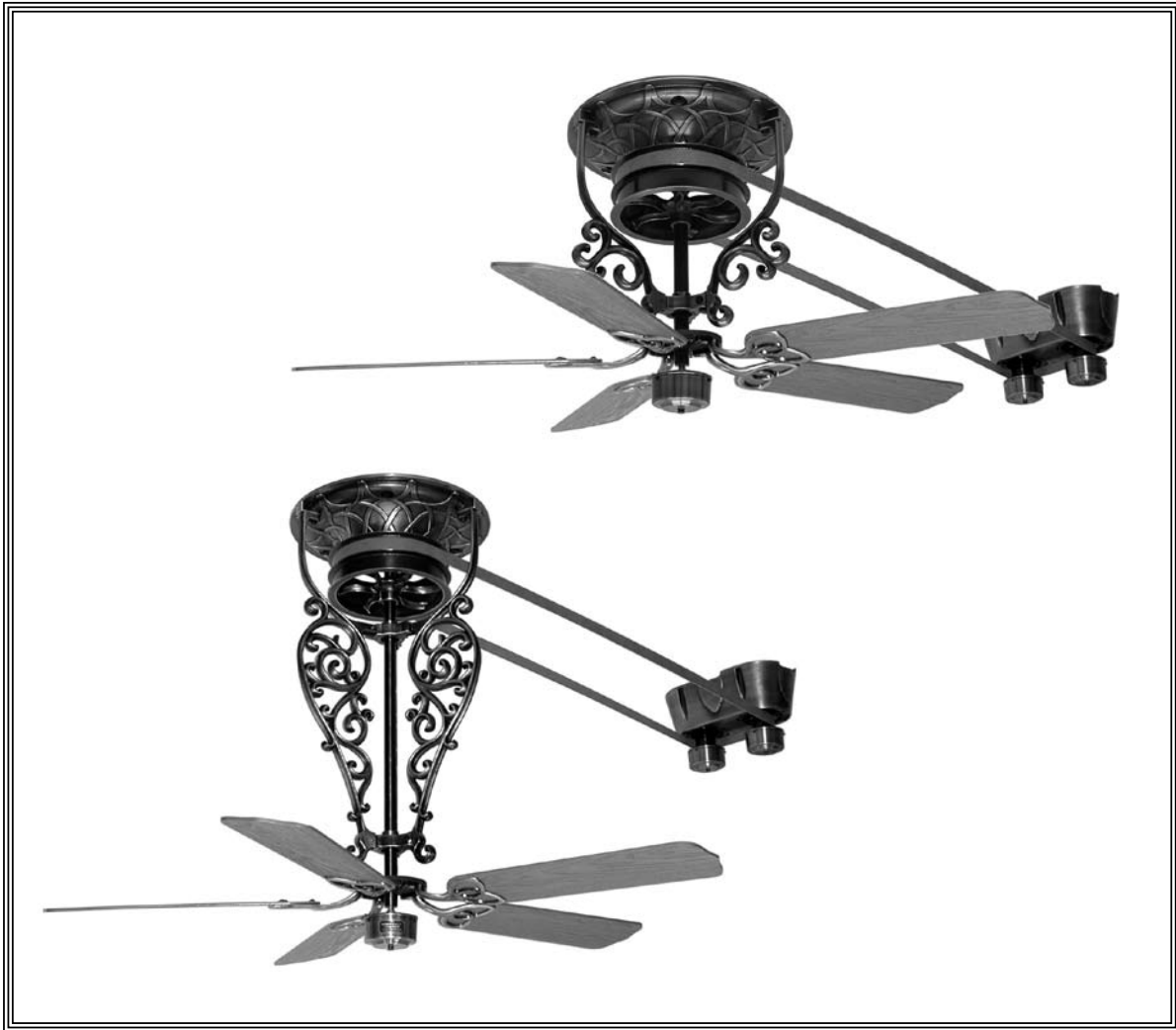

SPECIFICATION SHEET



celebrating 25 years

Product Specifications subject to change

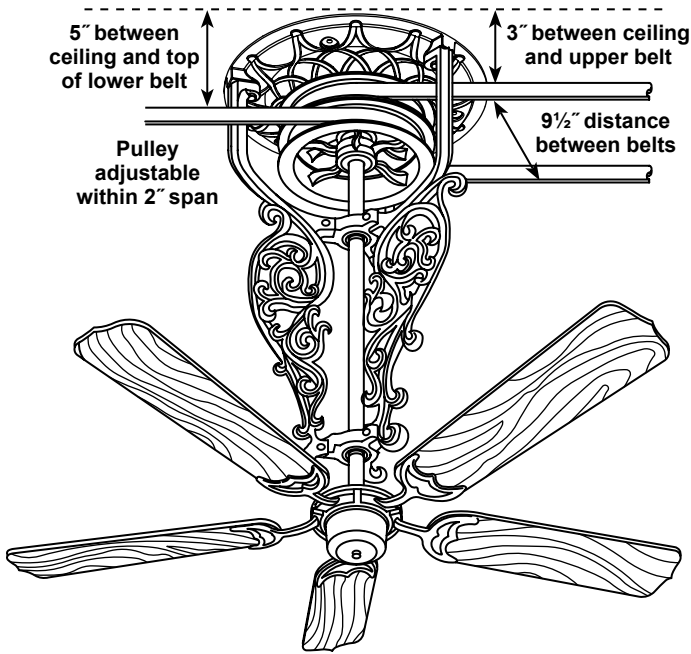

Long Fan Assembly – FP520**

Weight (basic Fan Unit only)	48 lbs
Ceiling Projection (w/o light kit)	36"
Blade Sweep (with FP1018 blades)	52"
Base Diameter (3-Hole Pattern Diameter)	16 ³ / ₄ " (13")

MOUNTING REQUIREMENTS

18" x 18" x 3/4" plywood backing able to support at least 100 lbs. Three 5/16" lag bolts are used to secure the fan base to the plywood backing. Flush mounted junction box placed on center (for light kit).

All dimensions shown in inches

Short Fan Assembly – FP510**

Weight (basic Fan Unit only)	38 lbs
Ceiling Projection (w/o light kit)	21"
Blade Sweep (with FP1018 blades)	52"
Base Diameter (3-Hole Pattern Diameter)	16 ³ / ₄ " (13")

MOUNTING REQUIREMENTS

18" x 18" x 3/4" plywood backing able to support at least 100 lbs. Three 5/16" lag bolts are used to secure the fan base to the plywood backing. Flush mounted junction box placed on center (for light kit).

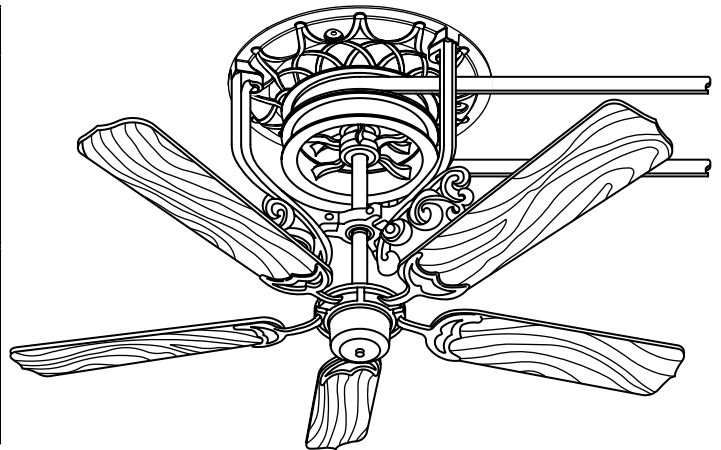

*All dimensions shown in inches
Belt dimensions are same as long fan assembly*

Ordering Information (Items Sold Separately)

Item	Catalog No.	Description
Fan Unit Assembly	FP510** FP520**	Short Pulley Assembly Long Pulley Assembly
Motor Unit Assembly	FP580**	Single-speed, reversible
Blades (Set of 5)	FP1018	Reversible Oak/Walnut 12° Blade Pitch
Idler	FP540** FP550**	Wall Mount Ceiling Mount

**Available Finish (codes)

AB	Antique Brass
BL	Black

**Insert Finish Codes

Motor Unit Assembly – FP580**	
Weight	26 lbs
Ceiling Projection	9"
Base Dimension	8" x 15½"
Max. Fan / Idler Units (combined per Motor)	6
MOUNTING REQUIREMENTS	
18" x 18" x ¾" plywood backing able to support at least 50 lbs. Flush mounted junction box placed on center.	
ELECTRICAL REQUIREMENTS	
A 120 Volts AC, 60 Hz, 15 amps circuit electrical feed, centered under the motor unit and wired to a standard wall switch (user supplied) is required. The motor unit will not operate more than 6 fan assemblies or idlers combined.	

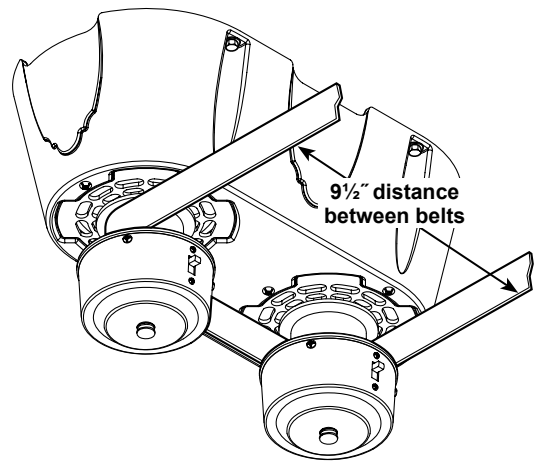

220V Model (Export version)
Motor Unit Assembly – 220 volt, 50 Hz Single-speed, reversible Finishes: available in 2 standard finishes

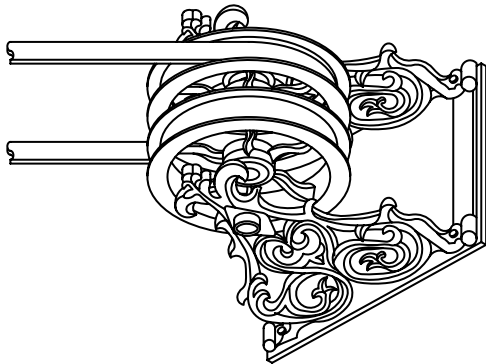

Idler / Wall Mount – FP540**	
Weight	20 lbs
Wall Projection	14½"
Base Dimension	14¾" x 8"
MOUNTING REQUIREMENTS	
18" x 18" x ¾" plywood backing able to support at least 50 lbs. Four 5/16" lag bolts are used to secure the idler base to the plywood backing.	

NOTE: Not required for most installations.

Idler / Ceiling Mount – FP550**	
Weight	15 lbs
Ceiling Projection	12"
Base Diameter (3-Hole Pattern Diameter)	16¾" (13")
MOUNTING REQUIREMENTS	
18" x 18" x ¾" plywood backing able to support at least 50 lbs. Three 5/16" lag bolts are used to secure the idler base to the plywood backing.	

NOTE: Not required for most installations.

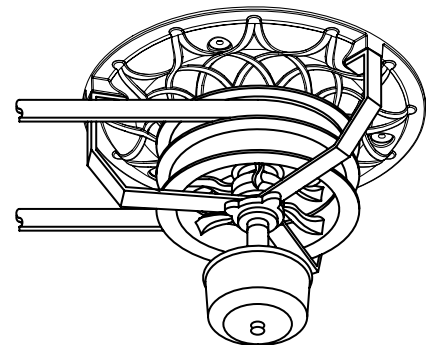

All dimensions shown in inches
Belt dimensions are same as long fan assembly

The Bourbon Street[®] Ceiling Fan Assembly

ELECTRICAL REQUIREMENTS:

Requires a grounded electrical supply line of 120 volts AC, 60 Hz, 15 amp circuit.

MOTOR SPECS:

Two FK2100 motors—1.8 amps combined, ceiling mounted, reversible (reverse switch located on switch cup housing). No more than 6 fan assemblies or idlers combined per motor. Not recommended for sound-sensitive areas. 220 VAC, 50 Hz, single-speed motor is also available.

FAN SPEED:

Single-speed—approximately 90 rpm.

UNIT SPACING:

6 ft. to 16 ft., although system configuration may affect the maximum spacing.

USE OF IDLERS:

Idler assemblies are utilized for the following circumstances:

- 1) When fan centers exceed 16 ft. (greater than 16 ft. may cause excessive belt sagging).
- 2) When obstacles prevent direct belting between two fan units.

PULLEY CONFIGURATION:

System layout will determine number of pulleys required. A typical fan assembly will have two pulleys located just below the fan base. In this configuration the pulley will have an adjustment range of approximately 2", allowing for small changes in ceiling elevation.

BELTING:

Belting material included with each system is 1/16" thick, 1-1/8" wide, 40' long 3-ply brown neoprene (belts are wrapped around the appropriate pulleys, pulled tight enough to remove slack, fastened with pop rivets (kit provided with system) and excess belt cut away. Belting will stretch some with time and use and may require retightened at a later date.

INSTALLATION HARDWARE:

Each system comes complete with all necessary installation hardware, with the exception of required plywood mounting platforms/backing (to be supplied by owner or contractor).

BLADES:

A variety of 4- and 5-blade sets are available. 5-blade sets are available in palm, bamboo, wood and composite materials. 4-blade sets are made of wood and require the use of BH20 series blade holders (not included). 4-blade sets will increase speed and airflow. See our catalog or visit www.fanimation.com for blade options.

LOCATION USE:

Fan and motor assemblies are dry location rated only.



Copyright 2009 Fanimation, Inc.

**10983 Bennett Parkway
Zionsville, IN 46077
Toll Free (888) 567-2055
FAX (866) 482-5215
Outside U.S. call (317) 733-4113
Visit Our Website www.fanimation.com**



2009/01